

# 305 X2-T -1

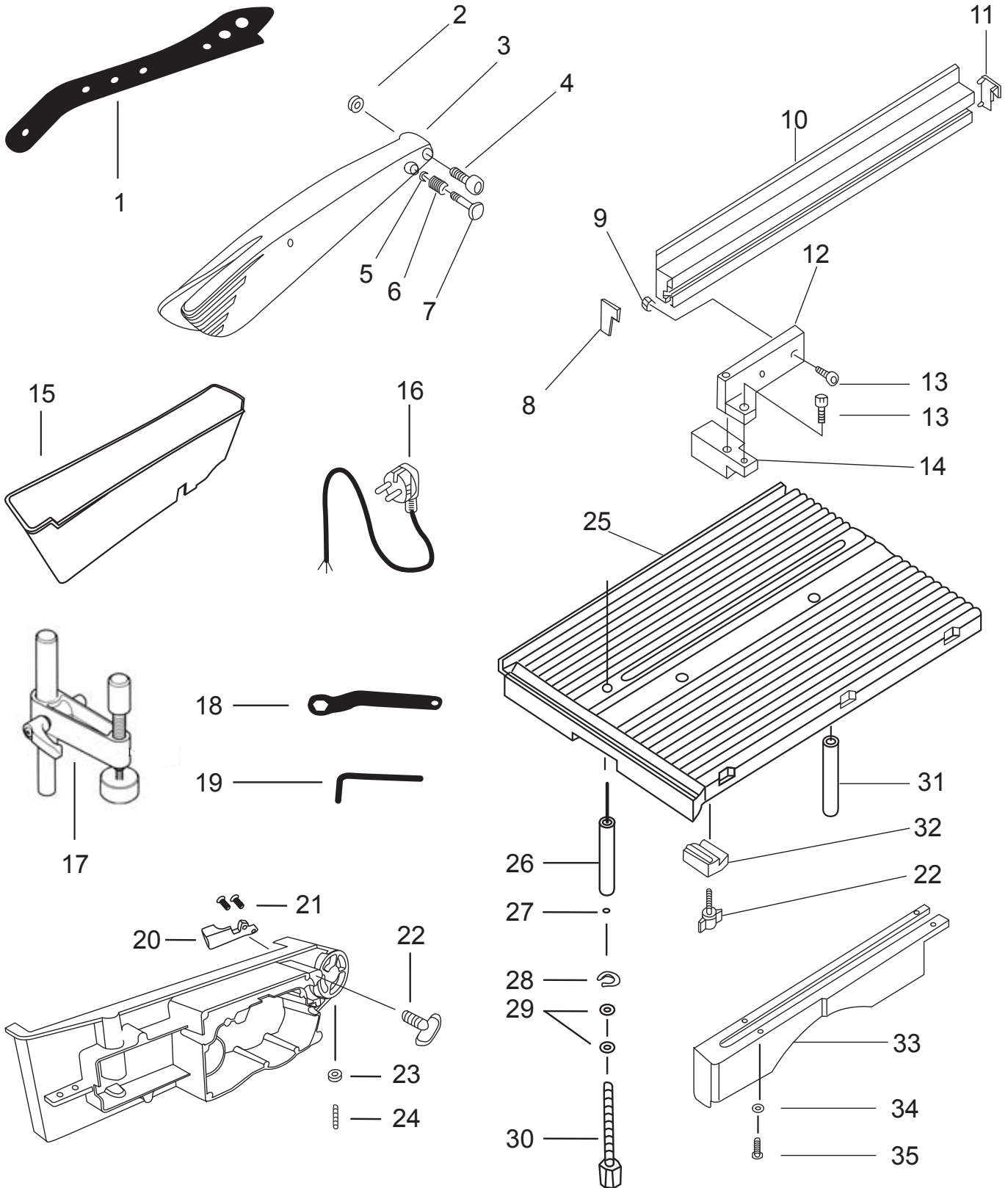

# 305 X2-T -2

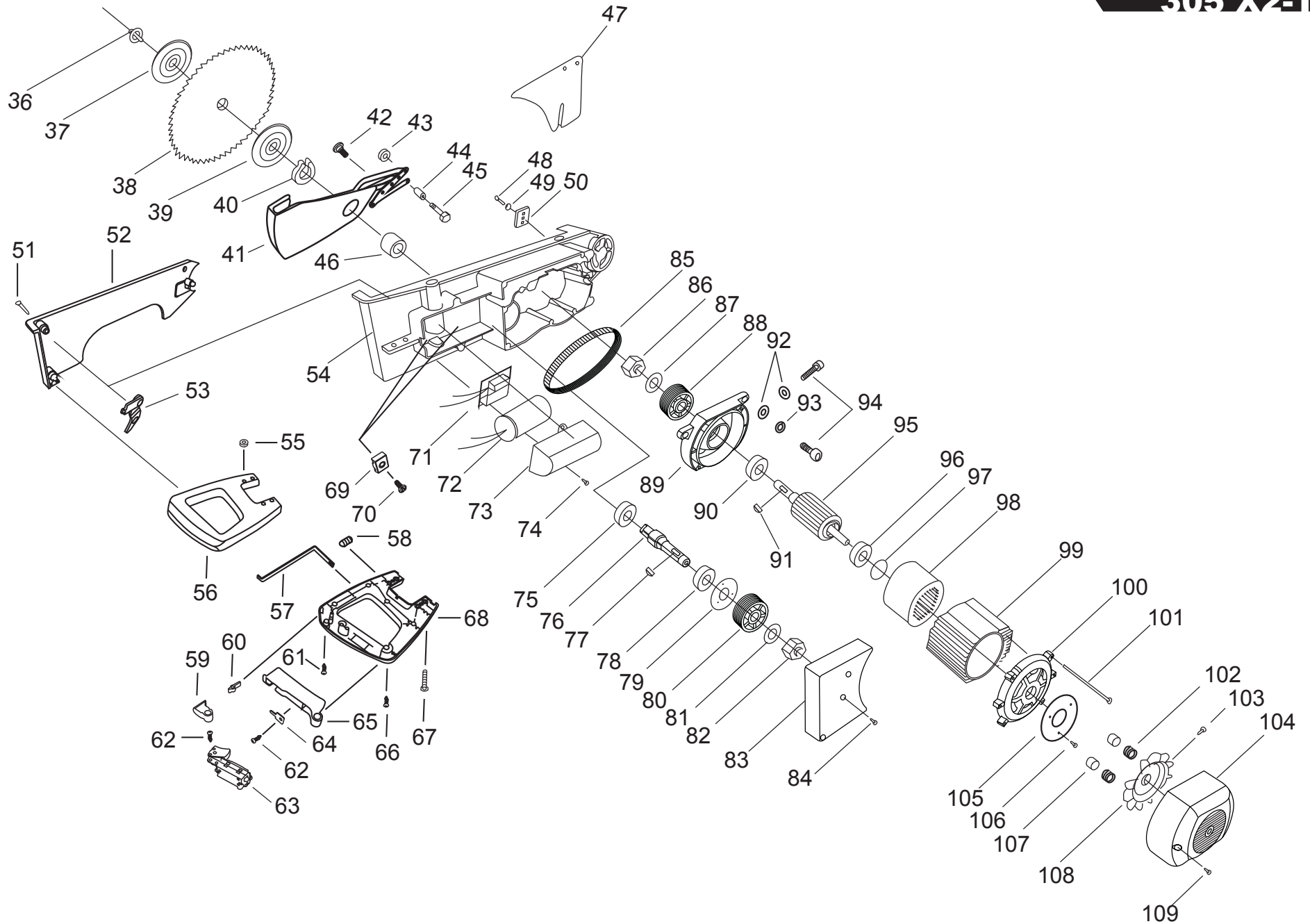

# 305 X2-T -3

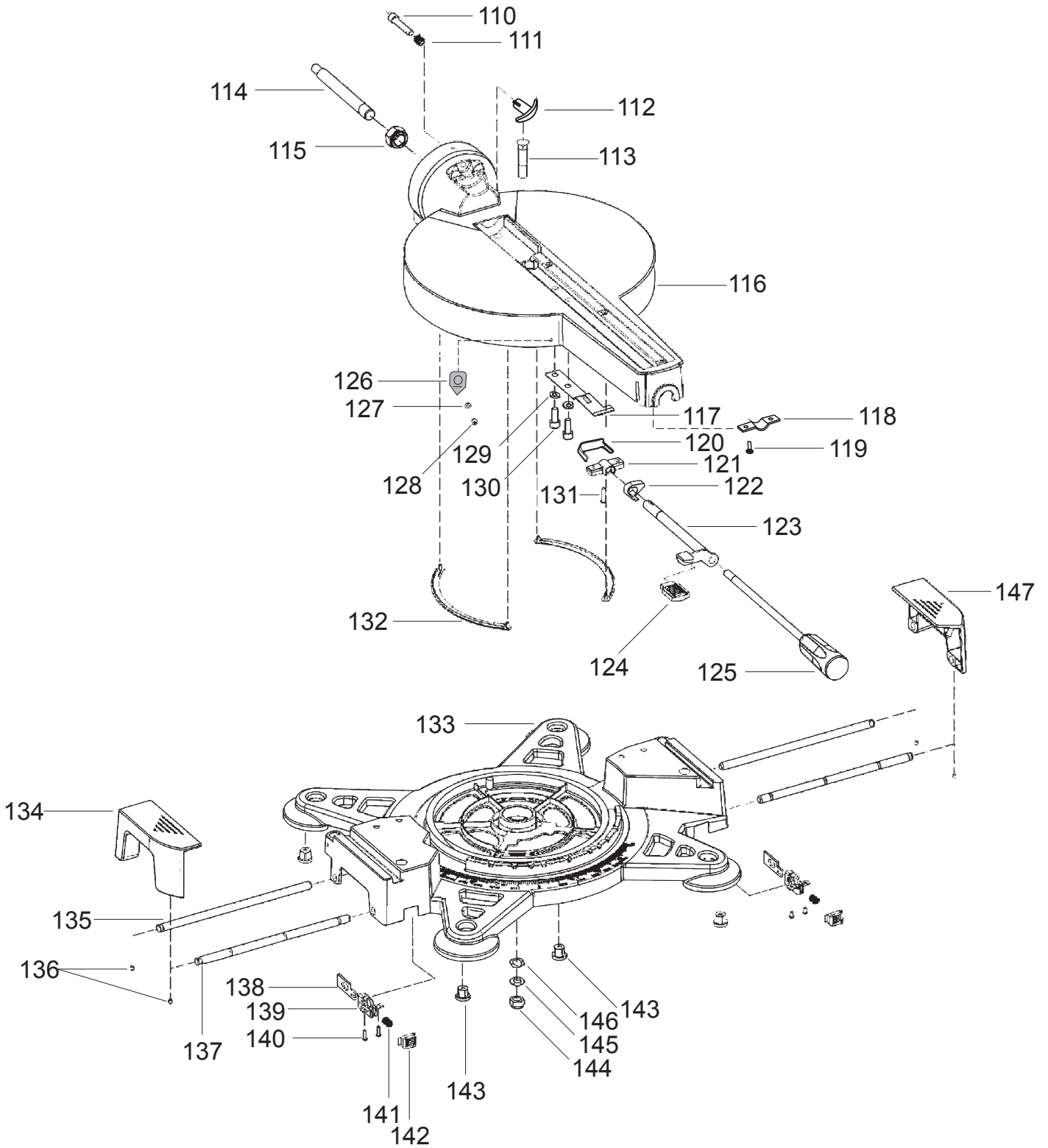

# 305 X2-T -4

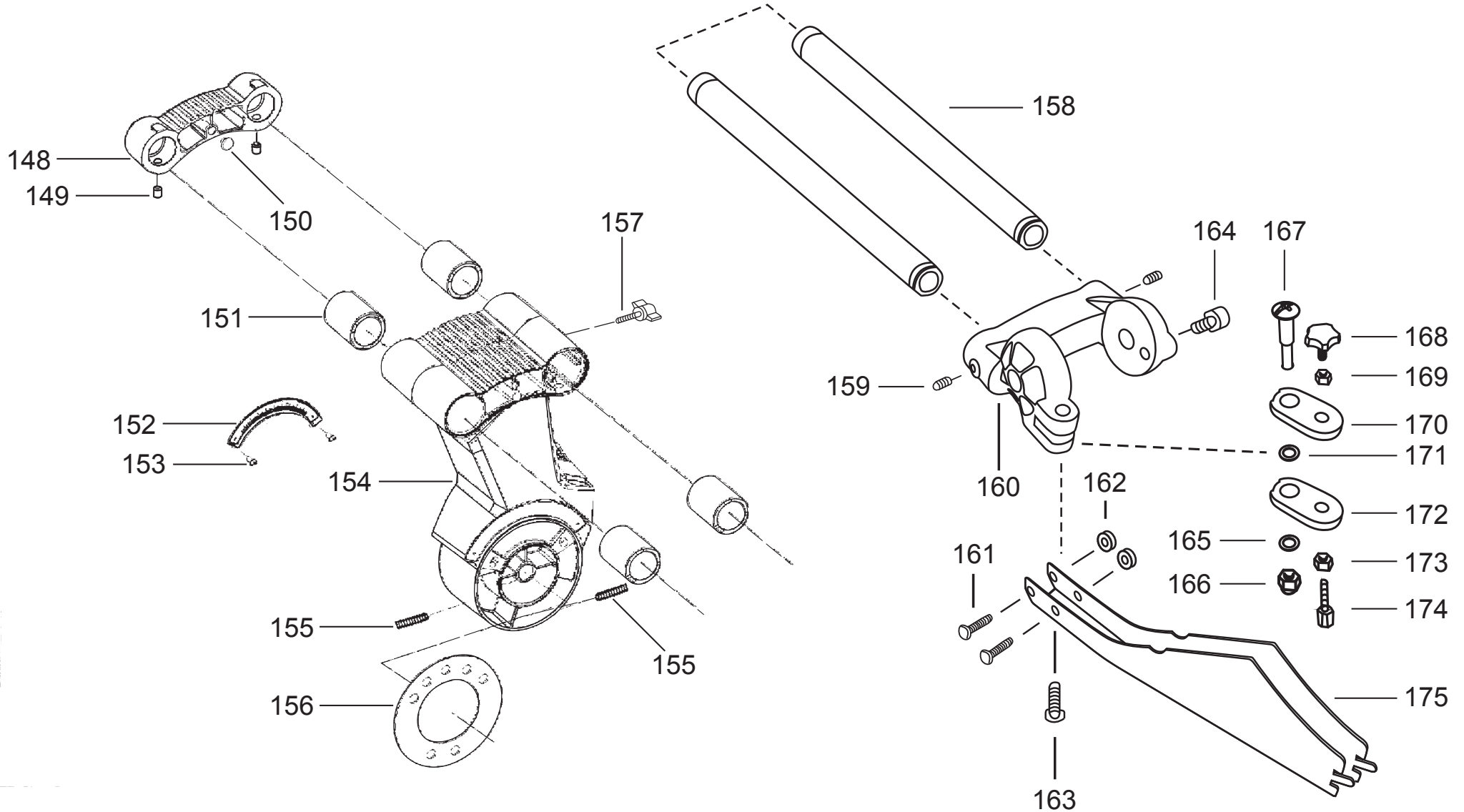

# 305 X2-T -5

